

Hi-MO X10

LR7-54HVD (Transparent design)

465~495M

- Simple design embodies modern style
- Highest efficiency with the best energy generation performance
- N-type TaiRay wafer & HPBC2.0 & 0BB innovative structure
- Anti-Shading & Prevent Localized Overheating

25 25-year Warranty for
Materials and Processing

30 30-year Warranty for Extra
Linear Power Output

Complete System and Product Certifications

IEC 61215, IEC 61730, UL 61730

ISO9001:2015: ISO Quality Management System

ISO14001: 2015: ISO Environment Management System

ISO45001: 2018: Occupational Health and Safety

IEC62941: Guideline for module design qualification and type approval

LONGI



24.5%
EFFICIENCY

0~3%
TOLERANCE

<1%
FIRST YEAR POWER
DEGRADATION

0.35%
POWER DEGRADATION

BC-CELL
LOWER OPERATING
TEMPERATURE

Additional Value

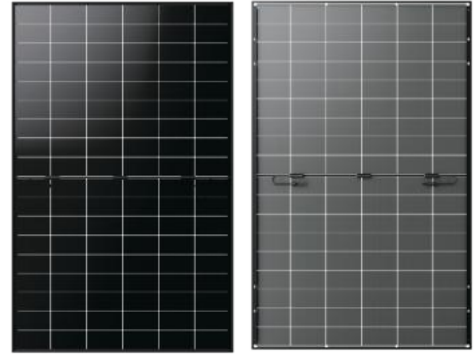
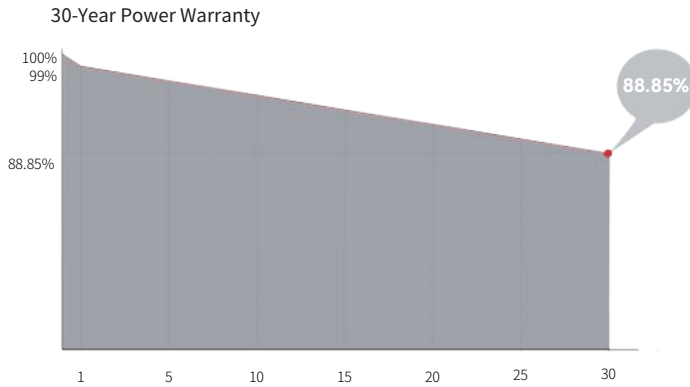

Mechanical Parameters

Cell Orientation	108 (6×18)
Junction Box	IP68, three diodes
Output Cable	4mm ² , +400, -200mm/±1200mm length can be customized
Glass	Double glass 2.0mm coated tempered glass+1.6mm semi-tempered glass
Frame	Black anodized aluminum alloy frame
Weight	23.5kg
Dimension	1800×1134×30mm
Packaging	36pcs per pallet / 216pcs per 20' GP / 864pcs per 40' HC

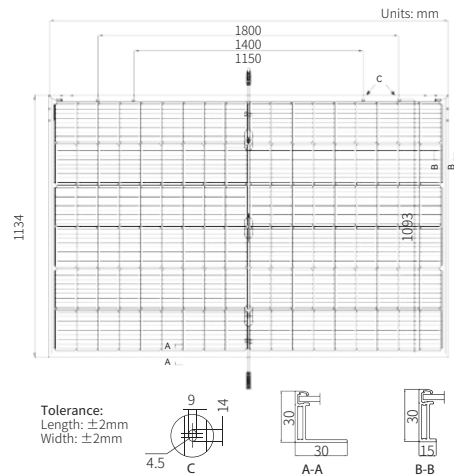

Electrical Characteristics

STC : AM1.5 1000W/m² 25°C

Test uncertainty for Pmax: ±3%

Module Type	LR7-54HVD-465M	LR7-54HVD-470M	LR7-54HVD-475M	LR7-54HVD-480M	LR7-54HVD-485M	LR7-54HVD-490M	LR7-54HVD-495M
Testing Condition	STC	STC	STC	STC	STC	STC	STC
Maximum Power (Pmax/W)	465	470	475	480	485	490	495
Open Circuit Voltage (Voc/V)	40.20	40.31	40.42	40.53	40.64	40.75	40.86
Short Circuit Current (Isc/A)	14.68	14.78	14.88	14.98	15.08	15.18	15.28
Voltage at Maximum Power (Vmp/V)	33.18	33.29	33.40	33.51	33.62	33.73	33.84
Current at Maximum Power (Imp/A)	14.02	14.13	14.23	14.33	14.43	14.53	14.63
Module Efficiency(%)	22.8	23.0	23.3	23.5	23.8	24.0	24.3

Operating Parameters

Operational Temperature	-40°C ~ +85°C
Power Output Tolerance	0 ~ 3%
Maximum System Voltage	DC1500V (IEC)
Maximum Series Fuse Rating	30A
Nominal Operating Cell Temperature	45±2°C
Protection Class	Class II
Bifaciality	70±5%
Fire Rating	IEC Class C

Mechanical Loading

Front Side Maximum Static	5400Pa
Loading Rear Side Maximum	2400Pa
Static Loading Hailstone Test	25mm Hailstone at the speed of 23m/s

Temperature Ratings (STC)

Temperature Coefficient of Isc	+0.050%/°C
Temperature Coefficient of Voc	-0.200%/°C
Temperature Coefficient of Pmax	-0.260%/°C